

## THE FATIGUE LIFE ESTIMATE BY THE LEFM CONCEPT OF THE TUBE JOINTS EXPOSED TO AXIAL LOAD

Jelena M. DJOKOVIĆ<sup>1)</sup>, Ružica R. NIKOLIĆ<sup>2), 3)</sup>,  
Ján BUJŇÁK<sup>4)</sup>, Branislav HADZIMA<sup>2)</sup>

<sup>1)</sup> University of Belgrade, Technical Faculty of Bor, Bor, Serbia

<sup>2)</sup> University of Žilina, Research Center, Žilina, Slovakia

<sup>3)</sup> University of Kragujevac, Faculty of Engineering, Kragujevac, Serbia

<sup>4)</sup> University of Žilina, Faculty of Civil Engineering, Žilina, Slovakia

**Keywords:** *tube joints, fatigue life, LEFM, Paris' law.*

### 1. Introduction

Steel structures, which are used in oil industry, mainly contain tube joints that are formed at the intersection of the lateral and main tubes of the same or different diameters. The great disturbances in the stress distribution and appearance of high stress concentrations appear on those tubes intersections. Due to that, the special attention must be devoted to design of the tube joints.

The crack growth in tube joints usually occurs along the weld's edge. That is the point where the main (longitudinal) tube (chord) and lateral tube (brace) intersect. The semi-elliptical crack appears in this area from the initial flaw that was created during the welding. The abrupt changes in the material's structure and responds to loading can increase the normal stresses in the transverse tube at certain spots around the intersection between the main and lateral tube, producing the "hot spot" stress. Sensitivity to fatigue depends on combination of the cyclic loading, initial defects, environmental influences and the "hot spot" stresses which are result of the walls' bending during the loading of a structure.

What concerns the sensitivity to fatigue, there exist two different approaches. The first one is the *S-N* method which is an empirical method that establishes the relation between the rank of the applied load and the fatigue working life. In this approach for the tube joints, it is necessary to establish the relation between the number of cycles (*N*) and the corresponding "hot spot" stresses (*S*). Thus, based on that, one obtains the stress versus working life curve which can be used for prediction of the remaining working life. The second approach for prediction of the crack propagation and working life of a structure is based on principles of the linear elastic fracture mechanics (LEFM). This method considers the growth rate of the existing defects in each individual phase of their growth, considering that in the welded structures the crack initiation phase takes a very small portion of the total working life; thus this technique is optimal for estimate of the working life of the welded structures.

The principles of the linear elastic fracture mechanics are applied in this paper for investigation of the crack behavior in the tube joints. That enables considering influence of various parameters (loading, geometrical characteristics, fatigue crack development, etc.)

separately and independently. It is also possible to estimate influence of the fatigue crack growth and, in that way, also influence on the working life of the welded joint.

Resistance of the welded joints, from the fracture mechanics aspect, was the subject of investigation for certain number of researchers. Atzori et al. [1] were investigating the possibility for unification of various criteria for analyzing the fatigue strength of the welded joints, based on influence of geometry on the local stress field and prediction of the remaining working life based on the linear elastic fracture mechanics. Motarjemi et al. [2] have analyzed influence of geometry of the main and attachment plates in the T and the cruciform welded joints exposed to tension. Lee et al. [3] have considered the weld's geometry influence on the fatigue life of the non-loaded cruciform welded joints. Baik et al. [4] have conducted an analysis of the fatigue crack growth propagation in the welded structures subjected to bending. Chattopadhyay et al. [5] have proposed a method that enables determination of the stress concentration and stress distribution in the area of the weld's root using the special technique of the shell finite method element. Shen and Choo [6] have determined the stress intensity factor of the welded tubes subjected to tensions. In paper Carpinteri et al. [7], the influence of notches on the fatigue life of double-curvature shells and round bars under the mode I loading are analyzed.

## 2. Calculation of the fatigue life of the welded tube joint

Geometry of the considered tube joint is presented in Fig. 1. The following assumptions were adopted for calculation of the fatigue working life: the crack shape is semi-elliptical, and there is only one crack which is propagating through the tube's thickness.

In engineering structures, especially in welded constructions, the most frequent are the semi-elliptical cracks. If the fracture mechanics principles are to be used to estimate the remaining working life of a structure, one must calculate the stress intensity factor (SIF).

The stress and strain fields at the crack tip are characterized by the stress intensity factors  $K_I$ ,  $K_{II}$  and  $K_{III}$  which are in the linear elastic fracture mechanics defined as:

$$K_I = \lim_{r \rightarrow 0} \sqrt{2\pi r} \sigma_{\theta\theta}, \quad K_{II} = \lim_{r \rightarrow 0} \sqrt{2\pi r} \sigma_{r\theta}, \quad K_{III} = \lim_{r \rightarrow 0} \sqrt{2\pi r} \sigma_{\theta z} \quad (1)$$

for  $\theta = 0$  where  $r$  and  $\theta$  are the polar coordinates with the origin at the crack tip.

The stress intensity factors depend on the shape of the sample and the way of loading. To calculate the stress intensity factor, one should determine the complete stress field at the crack tip and calculate the limit values in equation (1). For the practical purposes, this requirement takes too much time so usually some other approaches are being applied.

In general, the SIFs can be calculated in the following way (e.g. Hobbacher [8]):

$$K = \sigma \sqrt{\pi a} Y \quad (2)$$

where:  $\sigma$  is the reference loading (in tube joints that is the "hot spot" stress), and  $a$  is the crack length.

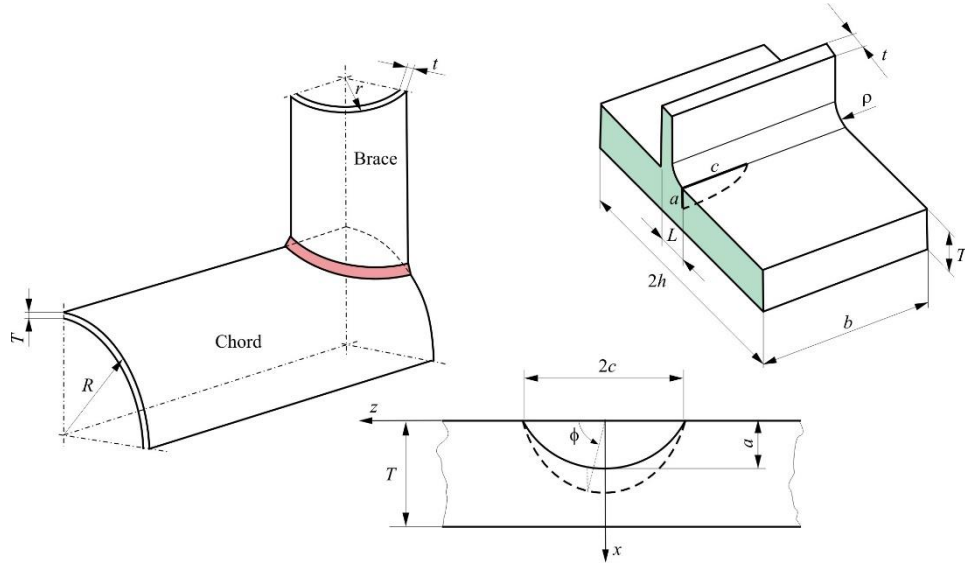

Fig. 1. Tube joint with the semi-elliptical crack along the weld's edge.

$Y$  is the dimensionless parameter which depends on the sample's geometry and applied load. For the semi-elliptical crack, it has the following form:

$$Y = \frac{\left( (a/c)^2 \cos^2 \varphi + \sin^2 \varphi \right)^{0.25}}{\left( 1 + 1.464(a/c)^{1.65} \right)^{0.5}}. \quad (3)$$

The unstable crack growth occurs when the stress intensity factor  $K_I$  becomes greater than the experimentally determined material characteristics  $K_{Ic}$  – fracture toughness. The crack growth equation provides the relationship between the crack increment  $\Delta a$  and increment of the number loading cycles  $\Delta N$ . Paris and Erdogan [9] have established that the change of the stress intensity factor can describe the subcritical crack growth in the fatigue loading conditions in the same way as the stress intensity factor describes the critical or the fast fracture. They determined that the crack growth rate is a linear function of the change of the stress intensity factor in the logarithmic diagram, i.e.

$$\frac{da}{dN} = C(\Delta K)^m \quad (4)$$

where:  $da$  is the change of the crack length which varies from the initial to the critical value that is causing the fracture,  $N$  is the number of the load cycles,  $C$  and  $m$  are the material constants, and  $\Delta K = K_{\max} - K_{\min}$  is the change of the stress intensity factor (i.e. the difference between the SIF values at maximal and minimal load).

The remaining working life is obtained by integration of equation (4):

$$N = \int_{a_i}^{a_{cr}} \frac{da}{C(\Delta K)^m} \quad (5)$$

where:  $a_i$  is the initial crack length and  $a_{cr}$  is the critical crack length.

### 3. Results and discussion

Variation of the stress intensity factor for the Mode I crack growth in terms of the relative crack depth  $a/T$ , calculated according to equations (2) and (3) for the three load levels of 150, 200 and 250 MPa, is shown in Fig. 2.

It can be seen from Fig. 2 that the stress intensity factor increases with the relative crack depth, all the way until it reaches 50 % of the wall thickness, and then the SIF decreases as the crack continues to propagate.

Diagram of the fatigue life (i.e. the number of cycles) dependence on the relative crack depth is shown in Fig. 3. The diagram is obtained by application of equations (3)-(5) and the programming package *Mathematica*<sup>®</sup>. Material's characteristics, used for the analysis, were the following:  $E = 210$  GPa and  $\nu = 0.3$ , while the material constants, needed for calculating the working life, were:  $m = 3$  and  $C = 2.92 \times 10^{-12}$ . The geometrical parameters are:  $r/R = 0.5$ ,  $t/T = 1$ ,  $\phi = 45^\circ$ ,  $c = 50$  mm. The diagrams presented in Fig. 3 are obtained for the three different load levels: 150, 200 and 250 MPa.

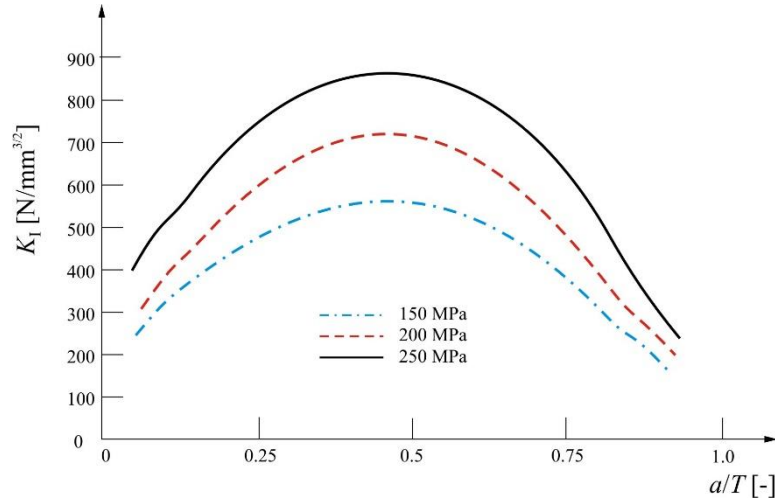

Fig. 2. Mode I stress intensity factor in terms of the relative crack depth  $a/T$ .

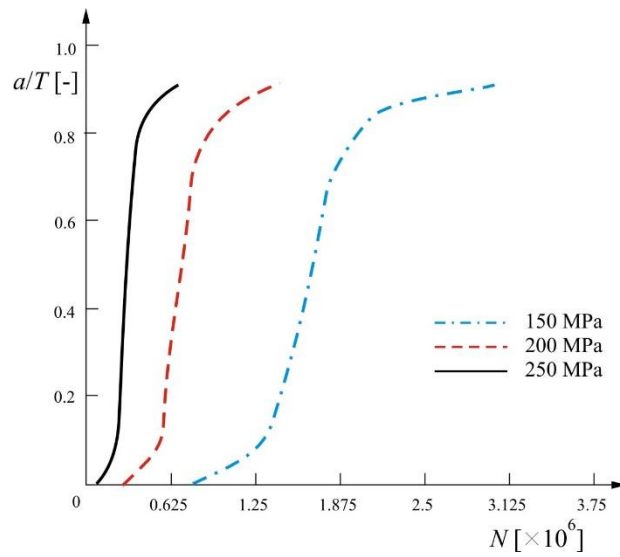

Fig. 3. Influence of the load on the fatigue life of the tube joint.

It could be noticed from Fig. 3 that the crack propagation during the initial phase of the wall tearing has the lower values of the  $da/dN$  since the values of the stress intensity factor are lower in that region. It can also be seen that the working life is decreasing with the load increase what is an expected result.

The dependence of the crack propagation rate on the relative crack depth is shown in Fig. 4.

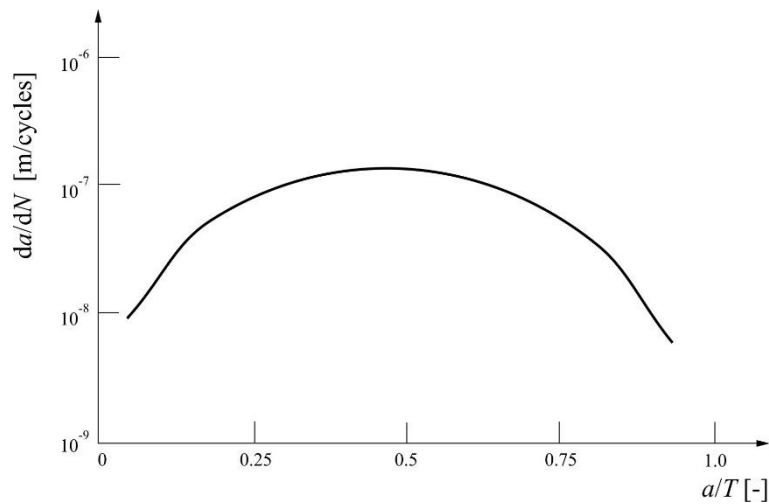

Fig. 4. The crack growth rate as a function of the relative crack depth.

From Fig. 4, one can notice that the crack propagation rate increases with the crack depth increase, while, after the depth reaches about 50 % of the wall's thickness, it starts to drop.

Such a trend is also exhibited by the Mode I stress intensity factor what leads to the conclusion that Mode I SIF is mainly responsible for the crack growth.

#### 4. Conclusions

The principles of the linear elastic fracture mechanics are applied in this paper for analysis of the crack behavior in the tube joints. Based on the conducted analysis, which implies several assumptions, one can deduce sufficiently relevant conclusions about the remaining working life of the welded tube joint.

It can be concluded from the presented diagrams that the stress intensity factor increases with the relative crack depth increase until it reaches about 50 % of the tube's wall thickness when the SIF starts to decrease as the crack continues to propagate. It can also be seen that the working life of the welded tube joint decreases with the load increase what represents the expected results, as well as that the Mode I SIF is mainly responsible for the crack growth.

#### Acknowledgement

Parts of this research were supported by European regional development fund and Slovak state budget by the project "Research Center of the University of Žilina – II phase" ITMS 313011D011 and by the Ministry of Sciences and Technology of Republic of Serbia through Grant ON174001.

#### Denotations of symbols

- $a$  – crack length, [m];
- $c$  – half-width of the crack, [m];
- $m$  – material constant, [-];
- $t$  – wall thickness of the tube, [m];
- $r$  – tube radius, [m];
- $C$  – material constant, its unit depends on the adopted value of  $m$  according to relation (4);
- $E$  – Young's modulus, [Pa];
- $K$  – stress intensity factor, [Pa·m<sup>1/2</sup>];
- $N$  – number of load cycles, [-];
- $R$  – tube radius, [m];
- $T$  – wall thickness of the tube, [m];
- $Y$  – dimensionless parameter characterizing the geometry of element, [-];
- $\nu$  – Poisson ratio; [-];
- $\sigma$  – reference stress loading the crack, [Pa];
- $\sigma_{\theta\theta}, \sigma_{r\theta}, \sigma_{\theta z}$  – components of stress tensor in polar coordinate system, [Pa].

#### Bibliography

- [1] Atzori B., Lazzarin, P., Tovo, R.: From the local stress approach to fracture mechanics: a comprehensive evaluation of the fatigue strength of welded joints, *Fatigue and Fracture of Engineering Materials and Structures*, 22 (1999), 369-382.

- [2] Motarjemi, A.K., Kokabi, A.H., Ziaie, A., Manteghi, S., Burdekin, F.M.: Comparison of the stress intensity factor of T and cruciform welded joints with different main and attachment plate thickness, *Engineering Fracture Mechanics*, 65 (2000), 55-66.
- [3] Lee, C.H., Chang, K.H., Jang, G.C., Lee, C.Y.: Effect of weld geometry on the fatigue life of non-load-carrying fillet welded cruciform joints, *Engineering Failure Analysis*, 16 (2009), 849-855.
- [4] Baik, B., Yamada, K., Ishikawa, T.: Fatigue crack propagation analysis for welded joint subjected to bending, *International Journal of Fatigue*, 33 (2011), 746-758.
- [5] Chattopadhyay, A., Glinka, G., El-Zein, M., Qian, J., Formas, R.: Stress analysis and fatigue of welded structures, *Welding in the World*, 55, 7-8, (2011), 2-21.
- [6] Shen W., Choo, Y. S.: Stress intensity factor for a tubular T-joint with grouted chord, *Engineering Structures*, 35 (2011), 37-47.
- [7] Carpinteri, A., Ronchei, C., Vantadori, S.: Stress intensity factors and fatigue growth of surface cracks in notched shells and round bars: two decades of research work, *Fatigue and Fracture of Engineering Materials and Structures*, 36 (2013), 1164-1177.
- [8] Hobbacher, A.: Stress intensity factors of welded joints, *Engineering Fracture Mechanics*, 46 (1993), 173-182.
- [9] Paris, P., Erdogan, F.: A Critical Analysis of Crack Propagation Laws, *Journal of Basic Engineering*, D85 (1963), 528-534.

### **Summary**

In the tube joints the crack growth usually appears along the weld's edge, i.e. at the spot where the chord and the brace are connected. The semi-elliptical crack the most frequently develops from the initial flaw that originated during the welding. The abrupt change in the material's structure and response to loading are increasing the normal stresses in the lateral tube at certain spots around the crossing of the main and lateral tubes, producing the "hot spot" stress. Sensitivity to fatigue depends on combination of the cyclic loading, initial defects, environmental influences and the "hot spot" stresses which are the result of the tube walls bending during the loading of the structure. The principles of the Linear Elastic Fracture Mechanics (LEFM) are applied in this paper to analysis of the crack propagation behavior of a thin tube joints. Influence of various parameters was investigated individually and independently, and the share of the fatigue crack growth and subsequently the working life of the welded joint were estimated.

